

USN

--	--	--	--	--	--	--	--	--	--

15ME64

Sixth Semester B.E. Degree Examination, July/August 2021 Design of Machine Elements – II

Time: 3 hrs.

Max. Marks: 80

- Note:** 1. Answer any FIVE full questions.
2. Use of design data hand book is permitted.
3. Assume missing data suitably.

- 1 a. A \perp section frame for a punch press is shown in Fig.Q.1(a). Determine the capacity of press if the maximum stress in the frame is not to exceed 60N/mm^2 . (08 Marks)

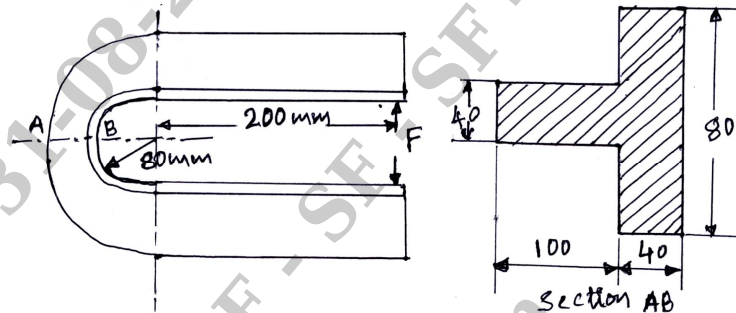

Fig.Q.1(a)

- b. The horizontal section of a crane hook is an isosceles triangle of 90mm deep, the inner width being 80mm. The hook carries a load of 40kN and the inner radius of curvature is 80mm. The load line is nearer to the inner surface of the hook by 20mm than the center of curvature at critical section. Find the extreme intensities of stresses at critical section. (08 Marks)
- 2 a. Calculate the maximum tangential stress induced when a 150mm diameter solid steel shaft is pressed fitted with a 300mm outer diameter cast iron hub having 200mm length. The maximum diametral interference due to the selected fit is 0.06mm. Take $E = 100\text{GPa}$ for cast iron and $E = 200\text{GPa}$ for steel. The Poisson's ratio for both cast iron and steel is 0.3 and the coefficient of friction is 0.12. Also find the axial force required to press the hub on the shaft and the torque that may be transmitted with this fit. (08 Marks)
- b. A cast iron cylindrical pipe of outside diameter 300mm and inside diameter 200mm is subjected to an internal pressure of 20N/mm^2 and external fluid pressure of 5N/mm^2 . Determine the tangential and radial stresses at the inner, middle and outer surface. Sketch the tangential and radial stress distribution across the thickness. (08 Marks)
- 3 a. A compressor requiring 90kW is to run at 250rpm. The drive is by V-belts from an electric motor running at 750rpm. The diameter of the pulley on the compressor shaft is 1m, while the center distance between the pulleys is limited to 1.75m. The belt speed should not exceed 1600 m/min. Determine the number of V-belts required to transmit the power if each belt has a cross sectional area of 375mm^2 and density of 1Mg/m^3 and has an allowable stress of 2.5N/mm^2 . The groove angle of the pulley is 35° and the coefficient of friction between the belt and pulley is 0.25. (08 Marks)
- b. A 20mm 8×19 steel wire rope is used with a hoisting drum of 1m diameter to lift a load of 20kN. The depth of the mine is 0.8km and the acceleration is 3m/s^2 . Determine the number of ropes required using a factor of safety 5. Neglect the tackle weight. (08 Marks)

- 4 a. A machine weighing 500kN is mounted on 10 springs in order to protect the building from vibrations. The section of the spring wire is rectangle with side ratio 1.6. Each spring has four active turns and the spring index is 6. Determine:
- Section of the spring so that longer side is parallel to the spring axis.
 - Deflection of the spring when the machine is stationary.
 - Shear stress induced if the shorter side is parallel to the spring axis.
- The allowable shear stress is 300MPa and the rigidity modulus is 82.7GPa. **(08 Marks)**
- b. A cantilever spring has 6 graduated leaves and 2 extra full length leaves. The effective length of the spring is 750mm and the leaves are 50mm wide. The spring is to sustain a load of 2.5kN and the corresponding deflection at the end of the spring is 60mm. Determine:
- Thickness of the leaves
 - Load shared by full length leaves
 - Load shared by graduated leaves
 - Stress in full length leaves
 - Stress in graduated leaves.
- Take $E = 206.8\text{GPa}$. **(08 Marks)**
- 5 It is required to transmit 15kW power from a shaft running at 1200rpm to a parallel shaft with speed reduction of 3. The center distance of shafts is to be 300mm. The material used for pinion is steel ($\sigma_d = 200\text{MPa}$) and for gear is cast iron ($\sigma_d = 140\text{MPa}$). The service factor is 1.25 and the tooth profile is 20° full depth involute. Design the spur gear and check the design for dynamic and wear load. **(16 Marks)**
- 6 A pair of straight tooth right angled bevel gears transmitting 7.5kW at 300rpm of pinion. The pressure angle is 20° . The pitch diameters of pinion and gear at their larger ends are 150mm and 200mm respectively. The face width of the gears is 40mm. Determine the components of the resultant gear tooth force and draw free body diagram of forces acting on the pinion and gear tooth. **(16 Marks)**
- 7 A single thread steel worm rotates at 1800rpm, meshing with a 24 tooth phosphor bronze worm gear ($\sigma_0 = 103.5\text{MPa}$) transmitting 3kW to the output shaft. The worm pitch diameter is 75mm and tangential module of the gear is 6mm. The normal pressure angle is $14\frac{1}{2}^\circ$. The gear face width is 50mm.
- Find the mesh efficiency
 - Transmitted gear forces
 - Is the mesh sufficient to handle the loading
 - Find the power lost by friction.
- (16 Marks)**

- 8 a. Derive the expression for torque transmitted by disc clutch for i) Uniform pressure condition and ii) Uniform wear condition. **(08 Marks)**
- b. A differential band brake shown in Fig.Q.8(b), the brake is to sustain a torque of 425N-m. The coefficient of friction between the band and the drum is 0.153. Determine:
- Necessary operating force F
 - Width and thickness of the steel band if the safe tensile stress in the band is 55N/mm^2 .
 - Section of the brake lever if the allowable bending stress is 60N/mm^2 . Take the depth of lever as twice the width. **(08 Marks)**

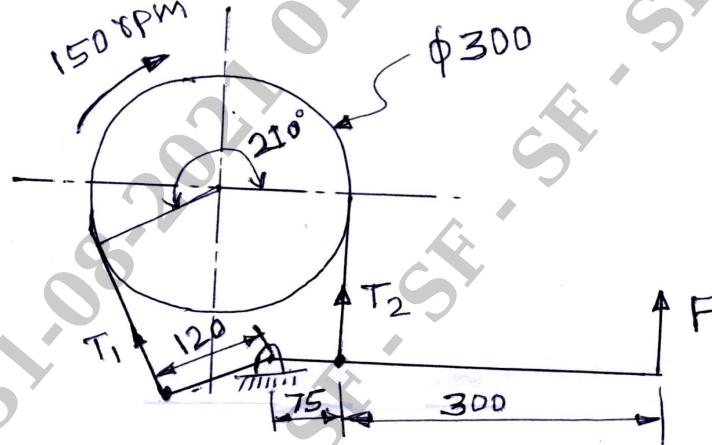

Fig.Q.8(b)

- 9 a. Derive Petroff's equation for a lightly loaded bearing. **(08 Marks)**
- b. A 75mm long full journal bearing of diameter 75mm supports a radial load of 12kN at shaft speed of 1800rpm. Assume ratio of diameter to diametral clearance as 1000. The viscosity of oil is $0.01\text{N/m}^2\text{s}$ at the operating temperature. Determine:
- Sommerfeld number.
 - Coefficient of friction based on McKee's equation.
 - Amount of heat generated. **(08 Marks)**
- 10 a. A single row deep ball groove ball bearing has a specific dynamic capacity of 45kN. The actual radial load $F_r = 8.5\text{kN}$. The speed of rotation is 1750rpm. What is the life in; i) in hours ii) cycles of operations iii) what is the average life? **(08 Marks)**
- b. Select suitable single row radial ball bearings to carry a radial load of 1.5kN and a thrust load of 1.2kN at 900rpm. The bearing is to be used 7 hours per day and average service life of 8 years is desired. Consider the design load for bearing during selection with speed factor, life factor, thrust factor and application factor. **(08 Marks)**
